

NLII-RH+T-IQRF | Combined RH/temperature sensor with IQRF

Room sensor NLII-RH is used to continuously monitor the air quality inside buildings and then control ventilation (HVAC) systems according to current levels of air pollution. The sensor measures the relative humidity (RH) and temperature (T). It is suitable for living rooms, bathrooms, warehouses, ateliers etc.



- > measures RH and temperature
- > 2x analog voltage/current output
- > IQRF wireless communication
- > maintenance during operation is not required
- > long life and stability

Sensor type / order code	RH output	T output	SIM slot	IQRF module
NLII-RH+T-IQRF	0-10 V/0-20 mA/4-20 mA ¹⁾	0-10 V/0-20 mA/4-20 mA ¹⁾	*	-
NLII-RH+T-IQRF+	0-10 V/0-20 mA/4-20 mA ¹⁾	0-10 V/0-20 mA/4-20 mA ¹⁾	*	*

¹⁾ It is possible to select the desired type of analog output by a jumper on the electronics board.

Description

Measurement of the relative humidity is based on the principle of capacitive polymer sensor.

The sensor has built-in two separate analog outputs - one for the actual temperature and the other for the actual relative humidity.

So the sensor efficiently manages ventilation and heat recovery units, based on current room air quality.

The current air quality can easily be determined by looking at the three LED indicators.

The **eco** level means good indoor air quality necessary to achieve a sense of well-being and at the same time optimal energy costs for heating, ventilation or air conditioning.

For detailed information about IQRF, use the document [NLII-IQRF-Communication](#). For information on the communication protocol, use the document [NLII-Modbus-Communication](#).

Technical data

Parameter	Value	Unit
Supply voltage range	12 – 35	V DC
	12 – 24	V AC
Average consumption	0,2	W
RH measuring range	0 – 100 %	RH
RH accuracy 0 – 90 %	± 5 %	RH
RH accuracy 90 – 100 %	± 6 %	RH
T measuring range	0 – 50	°C
T accuracy	± 0,4	°C
Working temperature	0 to +50	°C
Working humidity non condensing	0 – 90 %	RH
Storage temperature	-20 to +60	°C
Expected lifetime	min. 10	years
Ingress protection	IP20	
Dimensions	90x80x31	mm

Explanation of abbreviations and technical terms can be found on our website in the [Glossary](#) section.



NLII-RH+T-IQRF | Combined RH/temperature sensor with IQRF

Analog output values versus actual RH

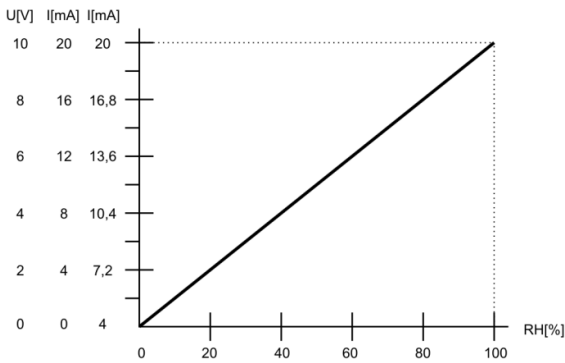

Analog output values versus actual T

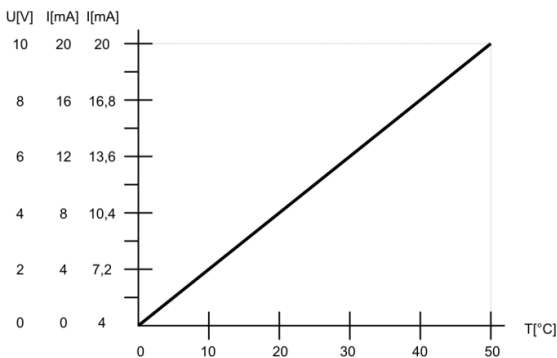

Typical T measurement accuracy

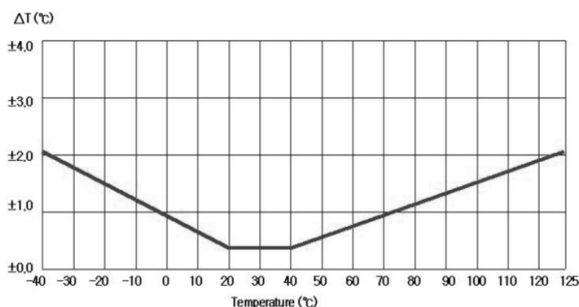

LED indication description

White LED lights:

- Less than 40 % RH or less than 18 °C.
(according to the quantity selected for indication)
- low concentrations of RH. Too dry air feels cooler as compared to equally hot but more humid air – risk of drying of the mucous membranes - respiratory problems
- low temperature and its higher fluctuation is not economically profitable

Green LED lights:

- More than or equal to 40 % RH or 18 °C, less than or equal to 60 % RH or 22 °C.
(according to the quantity selected for indication)
- optimal relative humidity for humans
- optimal balance of air quality and energy efficiency of ventilation and air conditioning

Yellow LED lights:

- More than 60 % RH or more than 22 °C.
(according to the quantity selected for indication)
- too high humidity, the risk of mold growth and associated health complications
- higher temperature T - high temperature can cause fatigue, restlessness, headache and feeling hot

Sensor start after power on

All three LEDs flash simultaneously until the first readings are available, but no longer than 10 seconds.

Sensor failure indication

All three LEDs are shining permanently.

CAUTION:

Warm-up: operational after 1 minute since power on. The declared accuracy is reached after 4 days of continuous power supply.

It is necessary to avoid severe mechanical shock of the sensor.



NLII-RH+T-IQRF | Combined RH/temperature sensor with IQRF

Electronic board controls and terminals

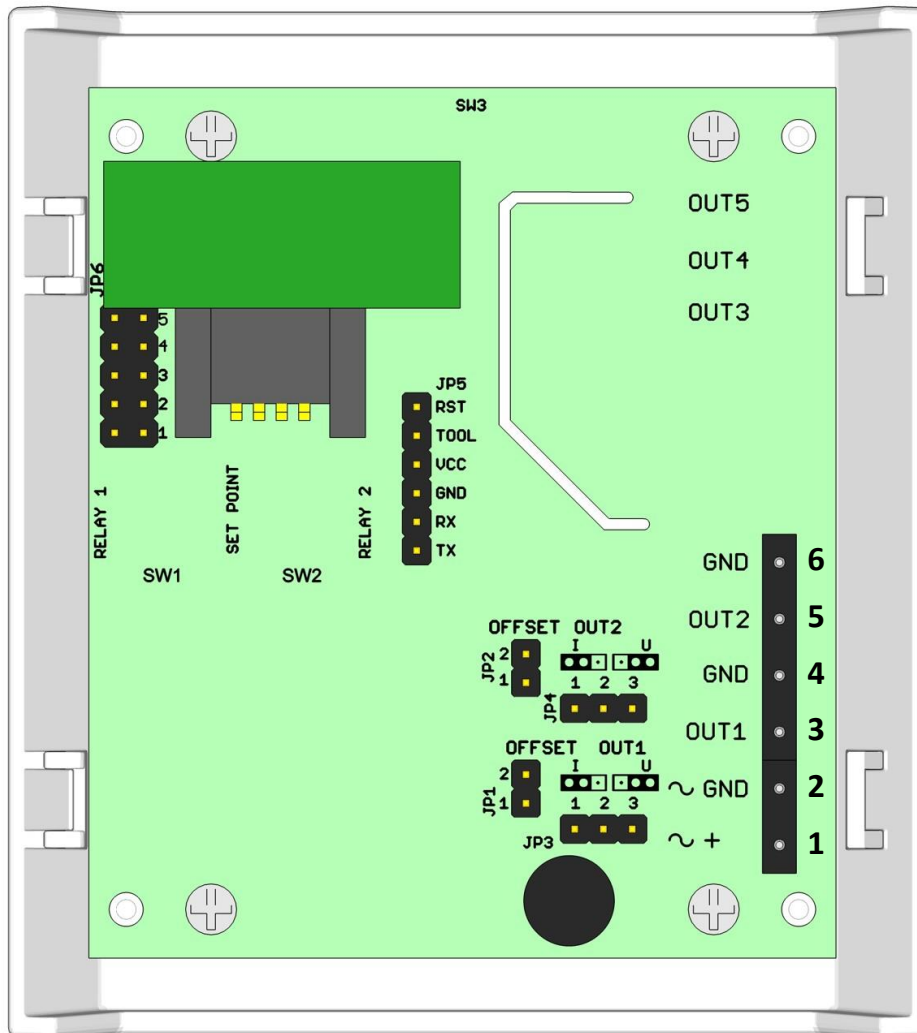

Terminals

- 1. ~ + supply AC or DC (+) plus pole
- 2. ~ GND supply AC or DC (-) minus pole, GND
- 3. OUT1 T sensor analog output, 0-10 V or 0-20 mA or 4-20 mA
- 4. GND T sensor output GND
- 5. OUT2 RH sensor analog output, 0-10 V or 0-20 mA or 4-20 mA
- 6. GND RH sensor output GND

Jumpers

- JP1 – Current output offset RH
- JP2 – Current output offset T
- JP3 – Voltage/current output T
- JP4 – Voltage/current output RH
- JP6 – LED indication settings



NLII-RH+T-IQRF | Combined RH/temperature sensor with IQRF

Jumpers on the electronics board

Mark	Description	Settings	Meaning
JP1	Current output offset RH - shift quiescent current from 0 mA to 4 mA	2 <input type="checkbox"/> 1 <input type="checkbox"/>	current output RH 0-20 mA
		2 <input checked="" type="checkbox"/> 1 <input type="checkbox"/>	current output RH 4-20 mA
JP2	Current output offset T - shift quiescent current from 0 mA to 4 mA	2 <input type="checkbox"/> 1 <input type="checkbox"/>	current output T 0-20 mA
		2 <input checked="" type="checkbox"/> 1 <input type="checkbox"/>	current output T 4-20 mA
JP3	Voltage/current output T - select the type of analog output - if voltage output T is selected, JP2 must not be shorted	1 2 3 <input type="checkbox"/> <input checked="" type="checkbox"/> <input type="checkbox"/>	voltage output T
		1 2 3 <input checked="" type="checkbox"/> <input type="checkbox"/> <input type="checkbox"/>	current output T
JP4	Voltage/current output RH - select the type of analog output - if voltage output RH is selected, JP1 must not be shorted	1 2 3 <input type="checkbox"/> <input checked="" type="checkbox"/> <input type="checkbox"/>	voltage output RH
		1 2 3 <input checked="" type="checkbox"/> <input type="checkbox"/> <input type="checkbox"/>	current output RH
JP6 - 1 JP6 - 3	LED indication LED signalization by VOC or RH - LED indication according to ambient light - when ambient light is dimmed (at night), LED indicators turn off automatically. - factory setting is indication by VOC	<input type="checkbox"/> <input type="checkbox"/> 5 <input type="checkbox"/> <input type="checkbox"/> 4 <input checked="" type="checkbox"/> <input checked="" type="checkbox"/> 3 <input type="checkbox"/> <input type="checkbox"/> 2 <input checked="" type="checkbox"/> <input checked="" type="checkbox"/> 1	LED indication by VOC
		<input type="checkbox"/> <input type="checkbox"/> 5 <input type="checkbox"/> <input type="checkbox"/> 4 <input checked="" type="checkbox"/> <input checked="" type="checkbox"/> 3 <input type="checkbox"/> <input type="checkbox"/> 2 <input checked="" type="checkbox"/> <input checked="" type="checkbox"/> 1	LED indication by RH permanent LED indication enabled
JP6 - 2 JP6 - 4 JP6 - 5	These positions are not intended for user setting.	<input type="checkbox"/> <input type="checkbox"/> 5 <input type="checkbox"/> <input type="checkbox"/> 4 <input type="checkbox"/> <input type="checkbox"/> 3 <input type="checkbox"/> <input type="checkbox"/> 2 <input type="checkbox"/> <input type="checkbox"/> 1	

Factory settings

LED indication: by RH, indication turns off
when ambient light dims

T analog output: voltage output

RH analog output: voltage output



NLII-RH+T-IQRF | Combined RH/temperature sensor with IQRF

Example of RH sensor connection for direct EC motor control using 0-10 V signal

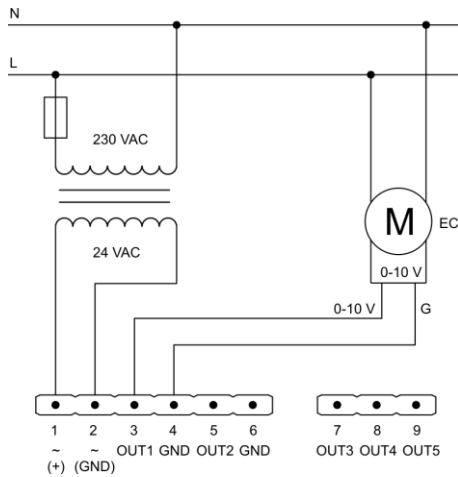

If you connect other devices to the same AC power source as the NL sensor, it is necessary to meet GND wiring of all analog inputs and outputs, as well as power wires.

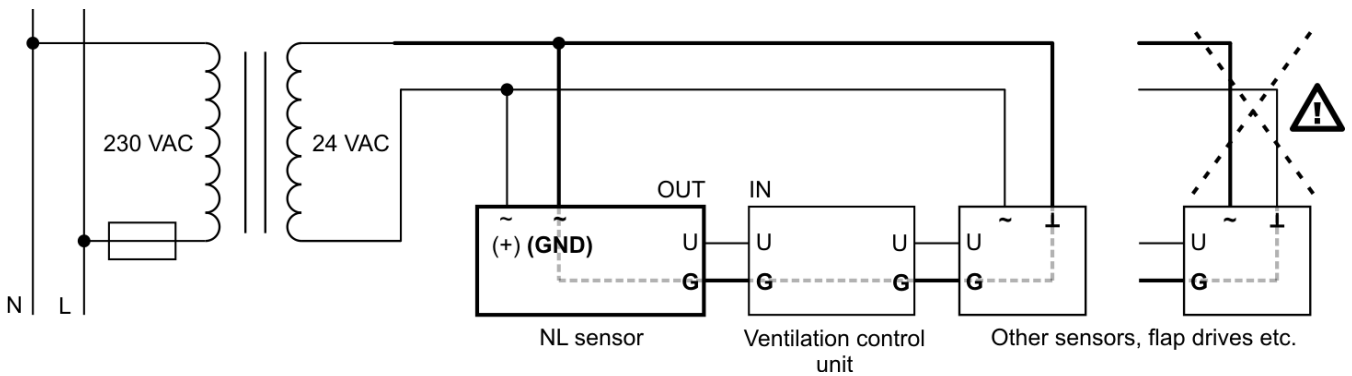

NLII-RH+T-IQRF | Combined RH/temperature sensor with IQRF

Sensor assembly



Box color

Front: White - RAL9016
Base: gray - RAL7035

Way to use

The product is intended for indoor use only. You can read the [recommendations for sensor placement](#) on our web pages.

End of product life

Discard the product in according to the electronic waste law and the EU directives.

Dimensions

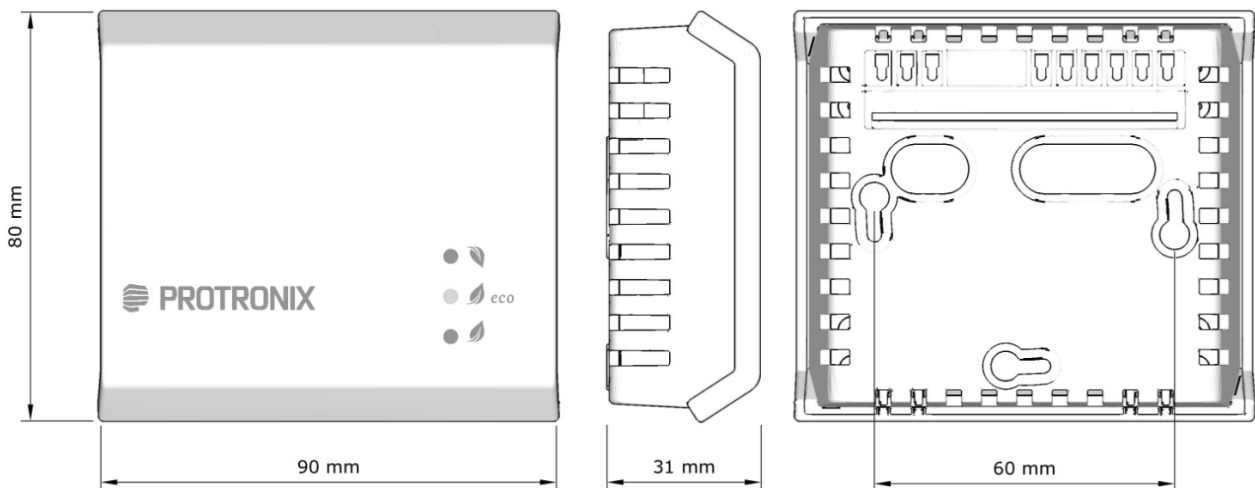

The producer reserves the right of technical changes in order to product improvements its properties and functions without previous notice.

