

## NLII-iVOC | Combined VOC/RH sensor

Room sensor NLII-iVOC is used to continuously monitor air quality inside buildings and then control ventilation (HVAC) systems according to current levels of air pollution. The sensor measures the concentration of gaseous organic substances in the air (VOC) and relative humidity (RH) of air. The sensor can be effectively used in offices, classrooms, restaurants, kitchens, fitness centres, commercial facilities etc.

- > measures VOC and RH
- > close to the human perception of odors
- > compatibility with CO<sub>2</sub> standard
- > 2x analog voltage/current output
- > 2x output relay – 2x NO/C
- > option for cascade relay switching



Type of sensor / order code	iVOC output	RH output	Relay
NLII-iVOC	0-10 V/0-20 mA/4-20 mA <sup>1)</sup>	-	-
NLII-iVOC-R	0-10 V/0-20 mA/4-20 mA <sup>1)</sup>	-	1x NO/C/NC
NLII-iVOC+RH	0-10 V/0-20 mA/4-20 mA <sup>1)</sup>	0-10 V/0-20 mA/4-20 mA <sup>1)</sup>	-
NLII-iVOC+RH-R	0-10 V/0-20 mA/4-20 mA <sup>1)</sup>	0-10 V/0-20 mA/4-20 mA <sup>1)</sup>	2x NO/C

<sup>1)</sup> It is possible to select the desired type of analog output by a jumper. Minimum achievable output value corresponds to minimum value of the measuring range.

### Description

Built-in advanced iVOC sensor is sensitive to volatile organic substances typically contained in the stuffy air - gaseous products of human metabolism and other gaseous pollutants such as formaldehyde, cooking vapors, fumes from paints, varnishes, adhesives, detergents, etc. that CO<sub>2</sub> sensor does not detect. NL-iVOC sensor detects those gaseous pollutant substances in the air that are the main reason for ventilation. Sensor NL-iVOC approximates to human perception of air quality. The output of the sensor is calibrated as equivalent to a standard CO<sub>2</sub> sensor with range 450 – 2000ppm.

Measurement of the relative humidity is based on the principle of capacitive polymer sensor.

The sensor has built-in two separate analog outputs - one for the actual concentration of VOC and the other for the current relative humidity.

If the sensor contains 2 relays, it can be set to two switching modes: standard (each relay switches according to its assigned quantity), a cascade mode (both relays switch according to one selected quantity and each one can be set to different switching level).

Cascade switching, for example, can be used to two-step switching of ventilation units output power. Relay trigger levels can be set independently by two rotary elements.

So the sensor efficiently manages ventilation and heat recovery units, based on current room air quality. The current air quality can easily be determined by looking at the three LED indicators.

The **eco** level means good indoor air quality necessary to achieve a sense of well-being and at the same time optimal energy costs for heating, ventilation or air conditioning.

Explanation of abbreviations and technical terms can be found on our website in the [Glossary](#) section.



## NLII-iVOC | Combined VOC/RH sensor

### Technical data

Parameter	Value	Unit
Supply voltage range	12 – 35	V DC
	12 – 24	V AC
Average consumption	0,5	W
iVOC measuring range <sup>1)</sup>	450 – 2000	ppm
iVOC relay - hysteresis	100	ppm
RH measuring range	0 – 100 %	RH
RH accuracy 20 – 80 %	± 3 %	RH
RH accuracy 0 – 100 %	± 6 %	RH
RH switching hysteresis	5 %	RH
Max. switching voltage	250/30	V AC / V DC
Max. switching current	5/5	A AC / A DC
Working humidity no condensing	5 – 95 %	RH
Working temperature	0 to +50	°C
Storage temperature	-20 to +50	°C
Expected lifetime	min. 10	years
Ingress protection	IP20	
Dimensions	90x80x31	mm
<sup>1)</sup> iVOC ppm equivalent to CO <sub>2</sub> ppm		

### iVOC sensor autocalibration function

Autocalibration compensates for long-term aging of the key components of the sensor. This function is available only when sensor power supply is continuous and uninterrupted. Calibration during operation is not necessary.

### Selected analog output values versus actual VOC concentration

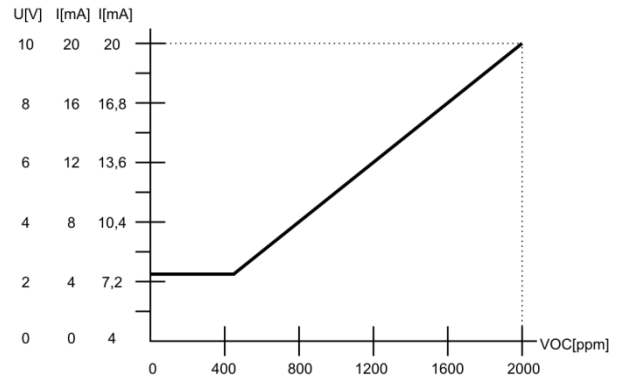

### Selected analog output values versus actual RH

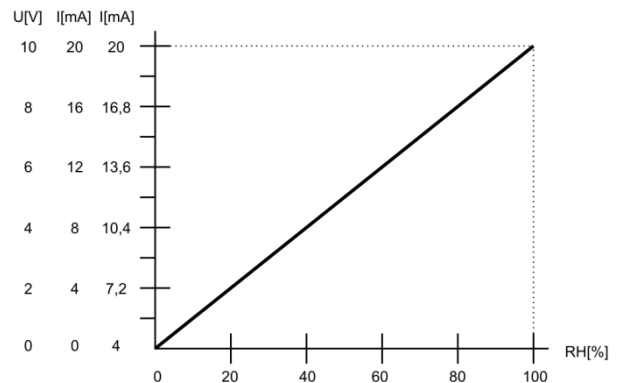

### Typical RH measurement accuracy at 25 °C

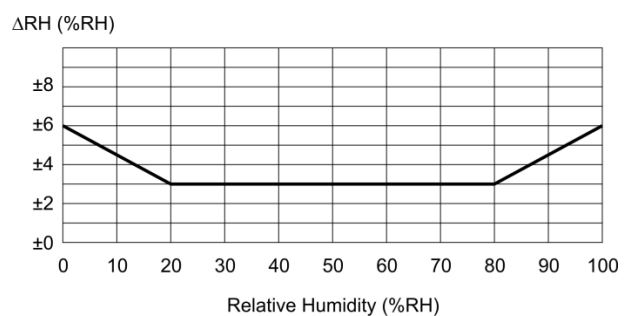

## NLII-iVOC | Combined VOC/RH sensor

### LED indication description

#### White LED lights:

- 
- Less than 600 ppm VOC or less than 40 % RH.  
(according to the quantity selected for indication)
- maintaining low concentrations of VOC is not cost-effective - slightly increased concentration does not cause any health complications
  - low concentrations of RH. Too dry air feels cooler as compared to equally hot but more humid air – risk of drying of the mucous membranes - respiratory problems

#### Green LED lights:

- 
- More than or equal to 600 ppm VOC or 40 % RH,  
less than or equal to 1200 ppm VOC or 60 % RH.  
(according to the quantity selected for indication)
- optimal balance of air quality and energy efficiency of ventilation and air conditioning
  - optimal relative humidity for humans

#### Yellow LED lights:

- 
- More than 1200 ppm VOC or more than 60 % RH.  
(according to the quantity selected for indication)
- higher concentration of VOC - further increase of VOC concentrations above this level can cause fatigue, restlessness, headache
  - too high humidity - the risk of mold growth and associated health complications

### Sensor start after power on

For 6 minutes after power on the sensor will warm-up. This state is indicated by simultaneous flashing of all three LEDs. The LEDs will show the condition of air according to LED indication description after the warm-up is done.

### Sensor failure indication

All three LEDs are shining permanently.

### CAUTION:

Warm-up: operational after 6 minutes since power on. The declared accuracy is reached after 4 days of continuous power supply.

It is necessary to avoid severe mechanical shock of the sensor.



## NLII-iVOC | Combined VOC/RH sensor

### Electronic board controls and terminals

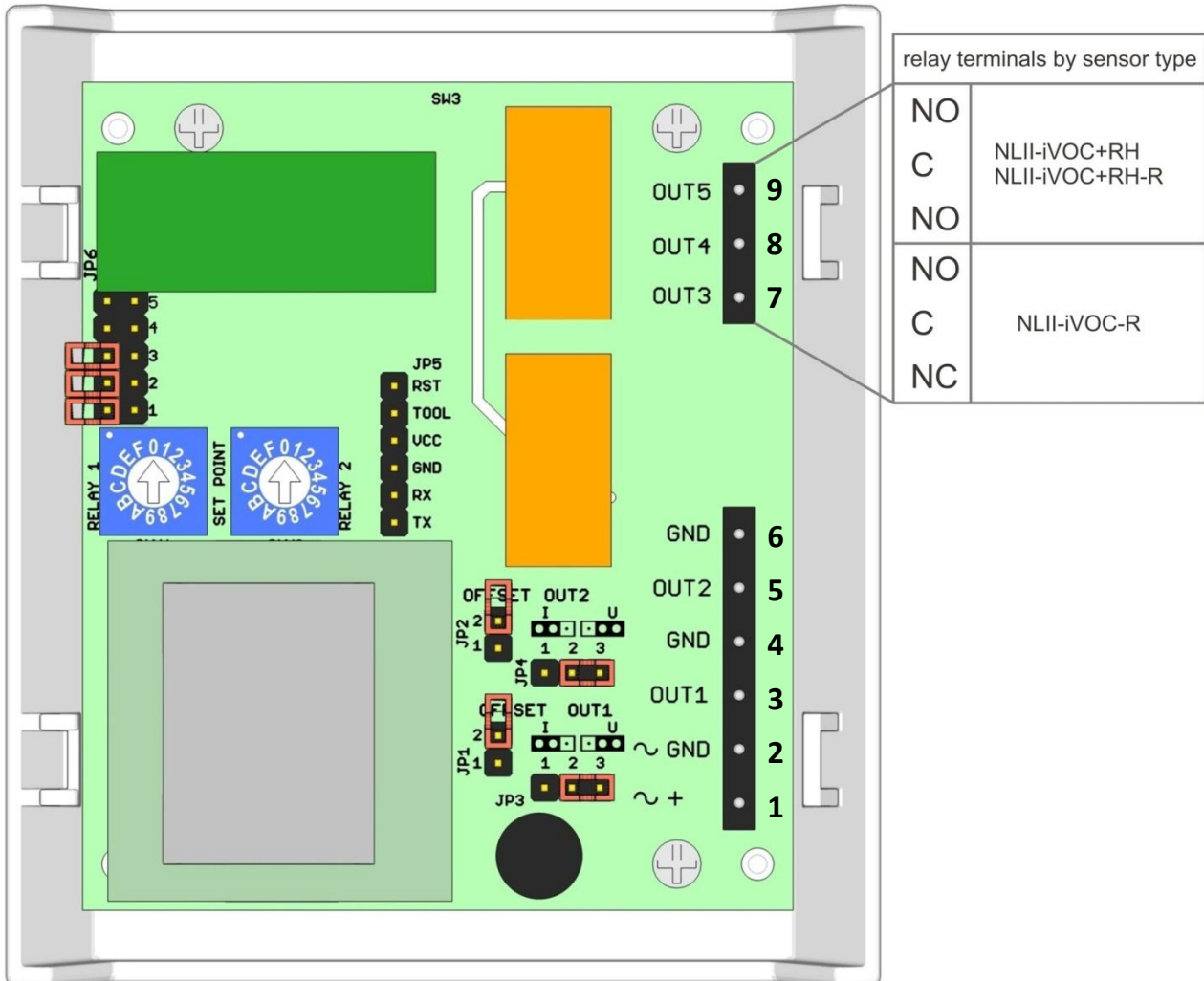

#### Terminals

- 1. ~ + power AC or DC (+) plus pole
- 2. ~ **GND** power AC or DC (-) minus pole, GND
- 3. **OUT1** VOC sensor analog output, 0-10 V or 0-20 mA or 4-20 mA
- 4. **GND** VOC sensor output GND
- 5. **OUT2** RH sensor analog output, 0-10 V or 0-20 mA or 4-20 mA
- 6. **GND** RH sensor output GND
- 7. **OUT3** NO relay 2 output, normally open (RH) (for NLII-iVOC-R it is a NC contact)
- 8. **OUT4** C output relay, common contact
- 9. **OUT5** NO relay 1 output, normally open (VOC)

#### SET POINT rotary switches for setting the relays switching levels

- RELAY 1** – level control switching for VOC
- RELAY 2** – level control switching for RH

#### Jumpers

- JP1** – Current output offset RH
- JP2** – Current output offset VOC
- JP3** – Voltage/current output VOC
- JP4** – Voltage/current output RH
- JP6** – LED indication and switching mode settings



## NLII-iVOC | Combined VOC/RH sensor

### Jumpers on the electronics board

Mark	Description	Settings	Meaning
JP1	<b>Current output offset RH</b> - shift quiescent current from 0 mA to 4 mA	2 ■ 1 ■	current output RH 0-20 mA
		2 ■ 1 ■	current output RH 4-20 mA
JP2	<b>Current output offset VOC</b> - shift quiescent current from 0 mA to 4 mA	2 ■ 1 ■	current output VOC 0-20 mA
		2 ■ 1 ■	current output VOC 4-20 mA
JP3	<b>Voltage/current output VOC</b> - select the type of analog output - if the selected voltage output is VOC, JP2 must not be shorted	1 2 3 ■ ■ ■	voltage output VOC
		1 2 3 ■ ■ ■	current output VOC
JP4	<b>Voltage/current output RH</b> - select the type of analog output - if the selected voltage output is RH, JP1 must not be shorted	1 2 3 ■ ■ ■	voltage output RH
		1 2 3 ■ ■ ■	current output RH
JP6 - 1	<b>LED indication</b> - LED indication according to ambient light - when ambient light is dimmed (at night), LED indicators turn off automatically.	■ ■ 5 ■ ■ 4 ■ ■ 3 ■ ■ 2 ■ ■ 1	permanent LED indication enabled
		■ ■ 5 ■ ■ 4 ■ ■ 3 ■ ■ 2 ■ ■ 1	LED indication according to ambient light



**NLII-iVOC | Combined VOC/RH sensor**

Mark	Description	Settings	Meaning
JP6 - 2 JP6 - 3	<p><b>Switching mode setting - standard/cascade.</b> <b>Selecting the sensor for switching and LED indication - VOC or RH.</b></p> <p>- if standard switching is selected, VOC and RH sensor control its own relay - if cascade switching is selected, the one chosen sensor controls both relays according to the levels set by the SET POINT rotary switches (for both switches the according switching levels table - VOC or RH, is applied)</p>	<p>□ □ 5 □ □ 4 ■ ■ 3 ■ ■ 2 □ □ 1</p>	switching and LED indication by VOC standard mode switching
		<p>□ □ 5 □ □ 4 ■ ■ 3 ■ ■ 2 □ □ 1</p>	switching and LED indication by RH standard mode switching
		<p>□ □ 5 □ □ 4 ■ ■ 3 ■ ■ 2 □ □ 1</p>	switching and LED indication by VOC cascade mode switching
		<p>□ □ 5 □ □ 4 ■ ■ 3 ■ ■ 2 □ □ 1</p>	switching and LED indication by RH cascade mode switching
JP6 - 4 JP6 - 5	<p><b>These positions are not intended for user setting.</b></p>	<p>■ ■ 5 ■ ■ 4 □ □ 3 □ □ 2 □ □ 1</p>	



## NLII-iVOC | Combined VOC/RH sensor

### Setting the relay switching using rotary switch SET POINT

The relay switches on when the measured variable level rises above the level of the rotary switch SET POINT.  
The relay switches off when the measured variable level falls below the level of the rotary switch SET POINT minus hysteresis value of 100 ppm.  
Minimal delay between changes in relays state is 2 minutes.

### Standard switching with one relay (NLII-iVOC-R)

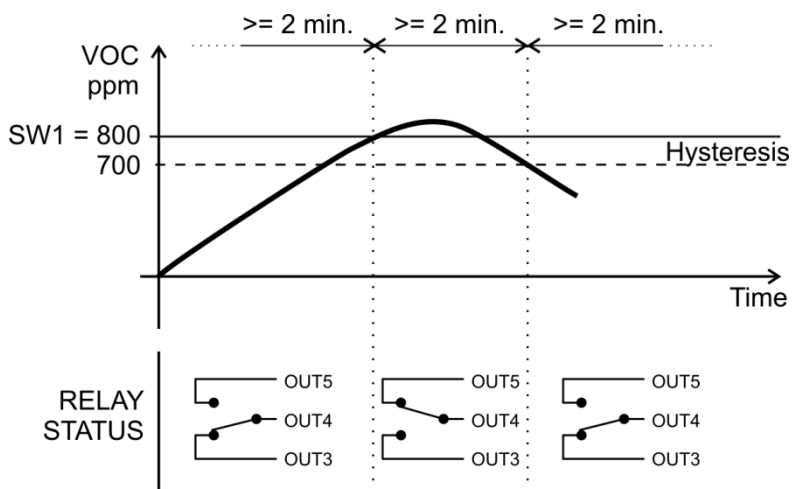

### Standard switching with two relays by VOC (NLII-iVOC+RH-R)

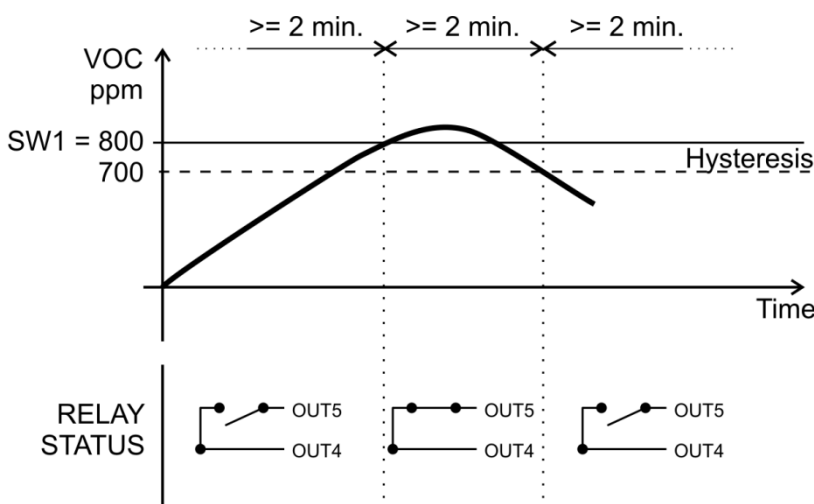

## NLII-iVOC | Combined VOC/RH sensor

### Standard switching with two relays by RH (NLII-iVOC+RH-R)

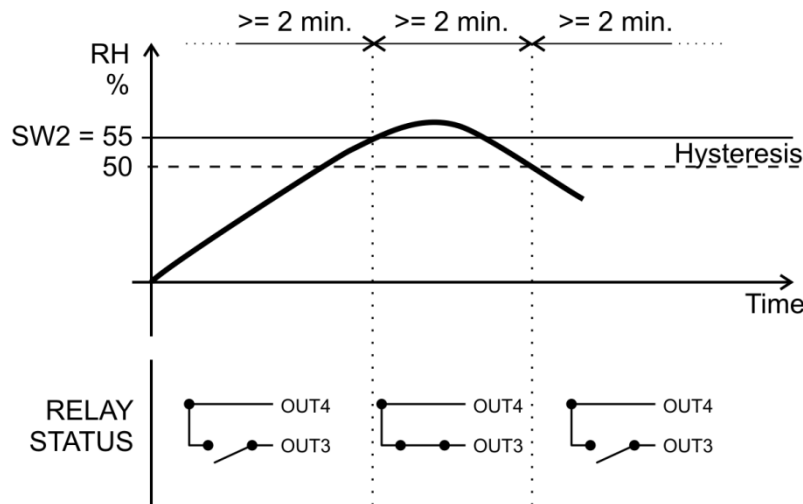

### Cascade switching with two relays by VOC (NLII-iVOC+RH-R)

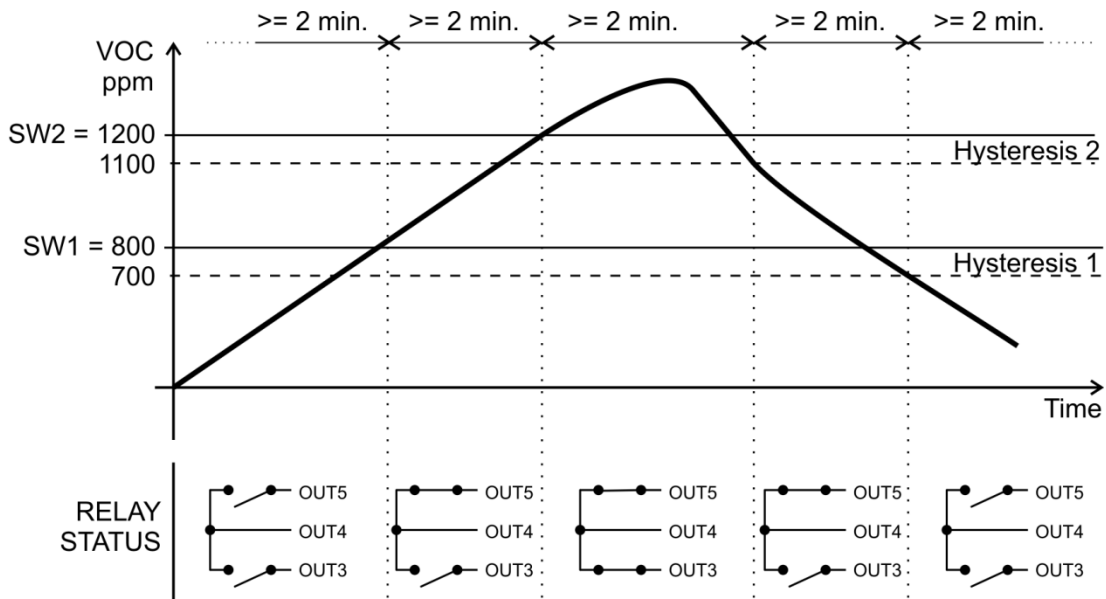



## NLII-iVOC | Combined VOC/RH sensor

### Setting the switching levels

Required concentration of VOC

SET POINT	VOC [ppm]
0	500
1	600
2	700
3	800
4	900
5	1000
6	1100
7	1200
8	1300
9	1400
A	1500
B	1600
C	1700
D	1800
E	1900
F	2000

Required relative humidity (RH)

SET POINT	RH [%]
0	relay off
1	10
2	20
3	30
4	40
5	50
6	60
7	70
8	80
9	90
A	35
B	45
C	55
D	65
E	75
F	85

Example for setting the concentration of 1000 ppm VOC:

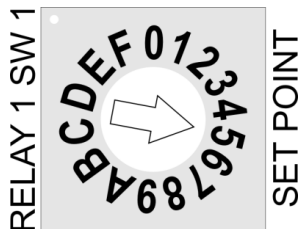

Example for setting a relative humidity of 55%:

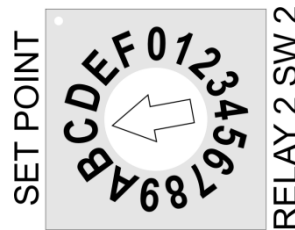

### Factory settings

LED indication: by VOC, indication turns off when ambient light dims  
 VOC analog output: voltage output  
 RH analog output: voltage output  
 Relay switching mode: Standard  
 Switching level VOC: 1000 ppm  
 Switching level RH: 55%



## NLII-iVOC | Combined VOC/RH sensor

**Example of VOC sensor connection with one relay (1x switching contact)**

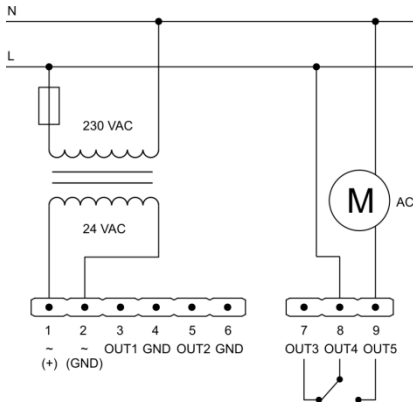

**Example of VOC sensor connection for direct EC motor control using 0-10 V**

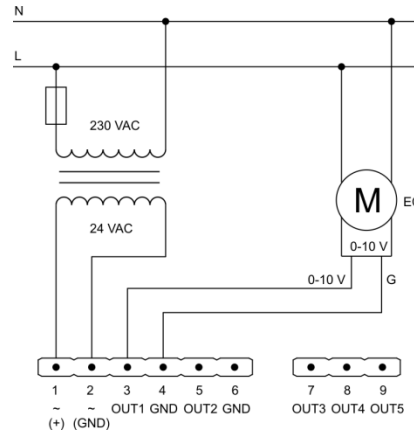

**Example of VOC sensor connection with two relays (2x NO/C)**

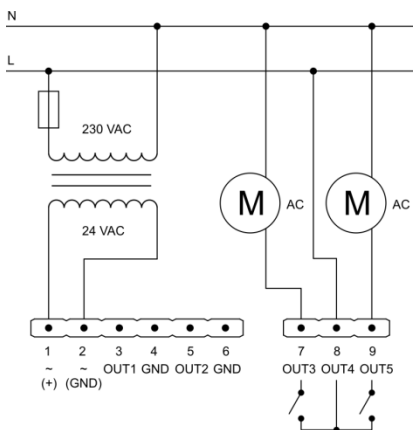

If you connect other devices to the same AC power source as the NL sensor, it is necessary to meet GND wiring of all analog inputs and outputs, as well as power wires.

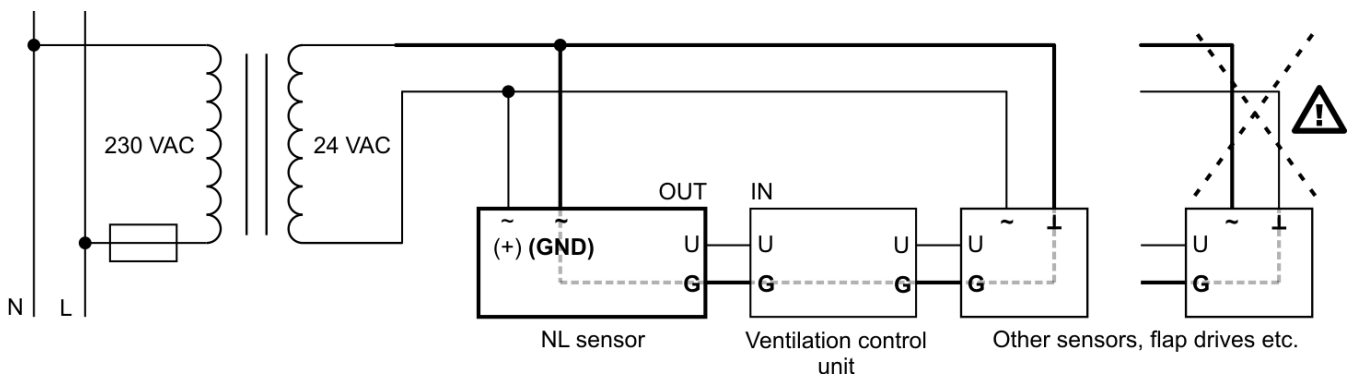

## NLII-iVOC | Combined VOC/RH sensor

### Sensor assembly



### Box color

Front: white - RAL9016  
Base: gray - RAL7035

### Way to use

The product is intended for indoor use only. You can read the [recommendations for sensor placement](#) on our web pages.

### End of product life

Discard the product in according to the electronic waste law and the EU directives.

### Dimensions

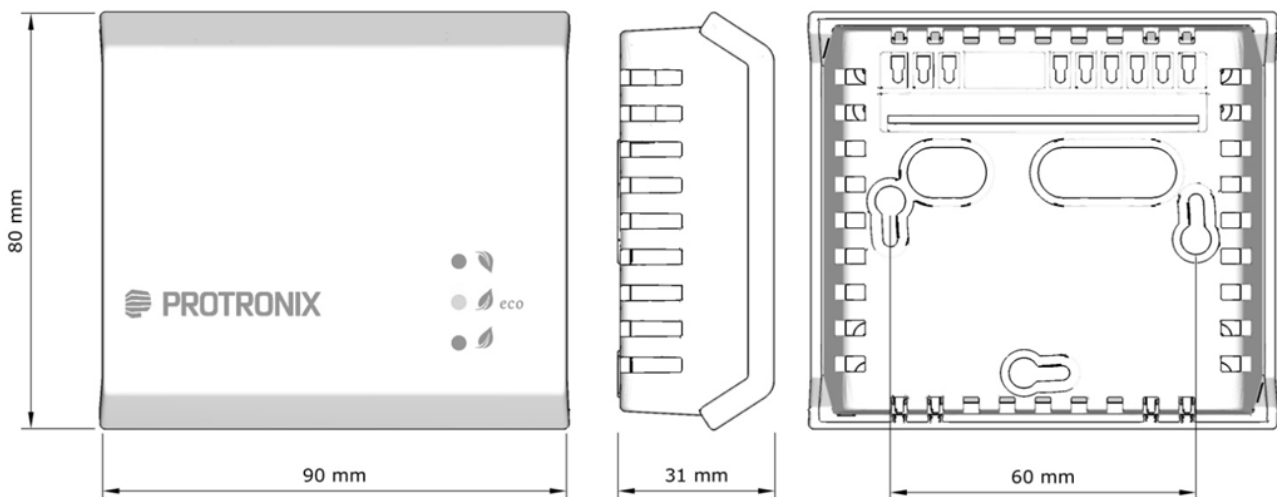

*The producer reserves the right of technical changes in order to product improvements its properties and functions without previous notice.*

