

## NL-ECO-TVOC | Room sensor VOC

Room sensor NL-ECO-TVOC is used to continuously monitor indoor air quality and for effective control of ventilation (HVAC) systems according to current air quality. The sensor monitors the concentration of VOC - Volatile Organic Compounds in air. It can be effectively used in restaurants, kitchens, fitness centres, toilets, changing rooms, gyms, offices, commercial buildings, schools, households etc.

- > monitors VOC
- > TVOC output in conformance with [EPA](#) and [UBA](#) standards
- > detects the true cause of ventilation demands
- > three-level LED indication
- > no disturbance at night – automatic turn off of LED indication
- > analogue voltage output 0-10V
- > three selectable TVOC ranges
- > [eCO<sub>2</sub>](#) output compatible with CO<sub>2</sub> standard
- > output relay C/NO
- > maintenance free during operation
- > long life and stability
- > wide range of supply voltage

### Description:

Built-in advanced VOC sensor is sensitive to volatile organic compounds typically contained in the exhausted air - gaseous metabolic products of human bodies and other gaseous pollutants such as formaldehyde, disinfectant vapours, cooking vapours, fumes from paints, varnishes, adhesives, detergents, cigarette smoke etc. that the CO<sub>2</sub> sensor does not detect.

There is possibility to select so called [eCO<sub>2</sub>](#) (estimated CO<sub>2</sub>) measurement mode. In this mode the sensor uses special algorithm to estimate CO<sub>2</sub> concentration based on the assumption that the TVOC produced by human metabolism is proportional to the exhaled CO<sub>2</sub>. The analogue voltage output of the sensor is adjusted as equivalent to a standard CO<sub>2</sub> sensor in range of 400–2000 ppm of estimated CO<sub>2</sub>. The trigger level of output relay can be set by a rotary element. Ventilation and heat recovery units can be directly controlled based on the output signal of sensor in the most efficient way.

Current air quality can be easily checked by three LED indicators.

Explanation of abbreviations and technical terms can be found on our website in the [Glossary](#) section.



Table of parameters:

Parameter	Value	Unit
Supply voltage range	12 – 35	V DC
	12 – 24	V AC
Consumption	max 1,5	W
Measuring range TVOC <sup>1)</sup>	0 – 1000	µg/m <sup>3</sup>
	0 – 3000	
	0 – 10000	
Measuring range eCO <sub>2</sub> <sup>1) 2)</sup>	400 – 2000	ppm
Relay - hysteresis	5% from selected range	
Voltage output <sup>3)</sup>	0 – 10	V DC
Max. switching voltage	250/30	V AC / V DC
Max. switching current	5/5	A AC / A DC
Working humidity non condensing	10 – 95 %	RH
Working temperature	0 to +50	°C
Storage temperature	-20 to +60	°C
Expected lifetime	10	years
Ingress protection	IP20	
Dimensions	90x80x31	mm

<sup>1)</sup> Output type and range can be set with jumpers. Factory setting range is TVOC 0 - 3000 µg/m<sup>3</sup>.  
<sup>2)</sup> Calculated estimated CO<sub>2</sub> concentration (estimated CO<sub>2</sub> - eCO<sub>2</sub>).  
<sup>3)</sup> Minimum achievable output value corresponds to minimum value of the selected measuring range.



## NL-ECO-TVOC | Room sensor VOC

### VOC sensor auto-calibration function

Built-in auto-calibration function compensates for long-term aging of the key components of the sensor. This function is active during permanent sensor power supply only.

Calibration during operation throughout the lifetime of the sensor is not needed.

For the correct function of the sensor, it needs contact with fresh air approximately once per 2 – 3 weeks.

### Analogue output voltage to TVOC dependency for the range 0 – 3000 $\mu\text{g}/\text{m}^3$

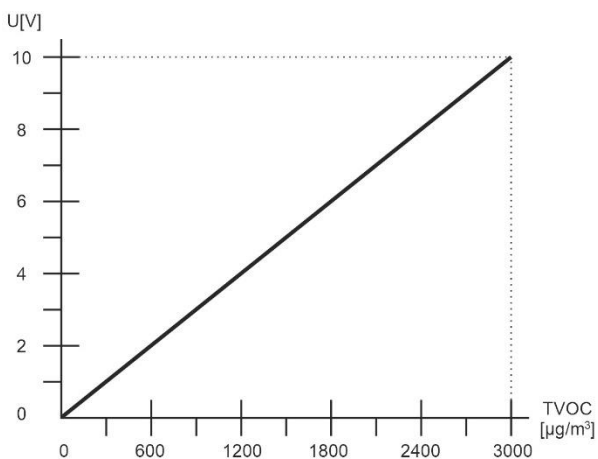

### Analogue output voltage to eCO<sub>2</sub> dependency for the range 400 – 2000 ppm



### LED indication description

#### White LED lights:

Less than 300  $\mu\text{g}/\text{m}^3$  TVOC.

Less than 600 ppm eCO<sub>2</sub>.



– excellent air quality, low concentrations of VOC

– maintaining this level is not cost-effective

#### Green LED lights:

More than or equal to 300  $\mu\text{g}/\text{m}^3$  TVOC, less than or equal to 1000  $\mu\text{g}/\text{m}^3$  TVOC.

More than or equal to 600 ppm eCO<sub>2</sub>, less than or equal to 1200 ppm eCO<sub>2</sub>.



– optimal balance of air quality and energy consumption for ventilation and air condition

#### Yellow LED lights:

More than 1000  $\mu\text{g}/\text{m}^3$  TVOC.

More than 1200 ppm eCO<sub>2</sub>.

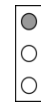

– lower air quality, that can cause fatigue, restlessness, headache and feeling uncomfortable, too hot etc.

### Sensor start-up after power on

Sensor warm up time is 2 hours after power supply connection.

More stabilised output is reached after 2 days of uninterrupted power supply, full stabilisation of sensor parameters is achieved after two weeks of uninterrupted power supply.

### Sensor failure indication

All three LED's lights up at the same time permanently.



**NL-ECO-TVOC | Room sensor VOC**

**Electronic board controls and terminals**

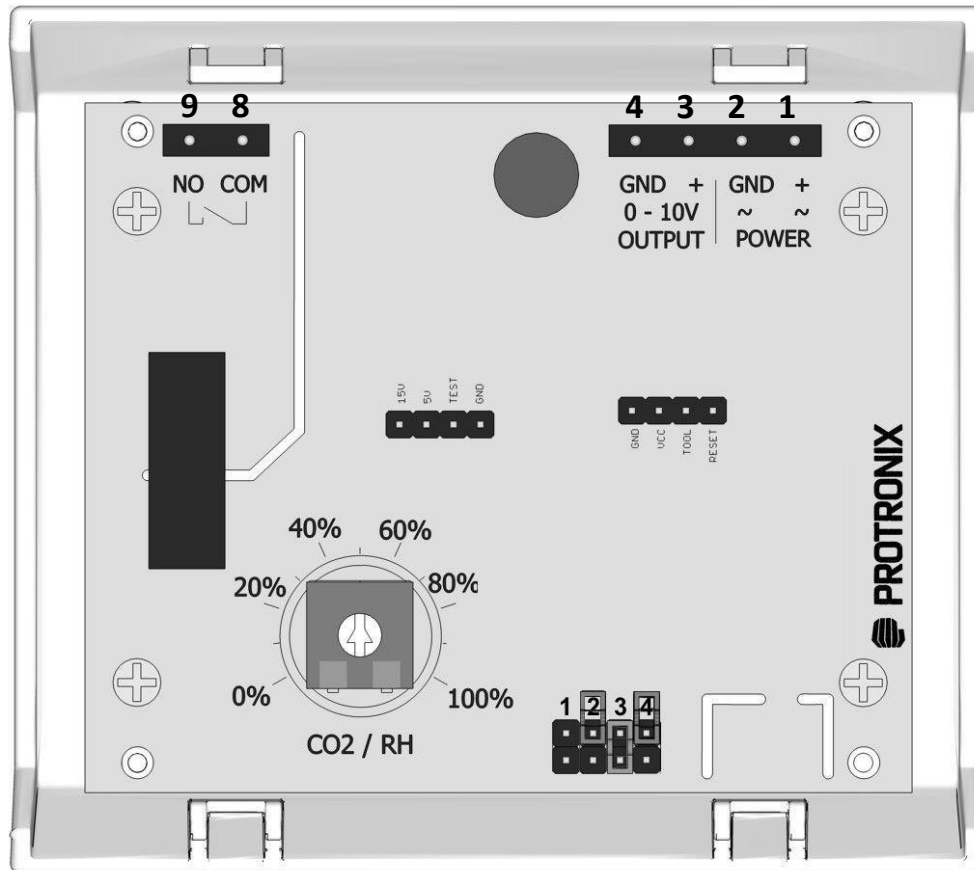

**Terminals**

**POWER**

<b>1. ~ +</b>	supply AC or DC (+) plus pole
<b>2. ~ GND</b>	supply AC or DC (-) minus pole, GND

**OUTPUT**

<b>3. +</b>	analog output 0-10 V
<b>4. GND</b>	output – minus pole



<b>8. COM</b>	output relay, common contact
<b>9. NO</b>	output relay, normally open contact

**Jumpers**

jumper	meaning	fitted	not fitted
<b>2</b>	LED indication	always	automatic
<b>1</b>	this position is not for user setting		

**0-10 V output configuration**

Output type	jumper <b>3</b>	jumper <b>4</b>
TVOC: 0 – 1000 µg/m <sup>3</sup>	-	✓
TVOC: 0 – 3000 µg/m <sup>3</sup>	✓	-
TVOC: 0 – 10000 µg/m <sup>3</sup>	✓	✓
eCO <sup>2</sup> : 400 – 2000 ppm	-	-

**Factory setting**

Output type	TVOC
Measuring range	0 - 3000 µg/m <sup>3</sup>
LED indication	automatic
Switching level	50%



## NL-ECO-TVOC | Room sensor VOC

### Setting the relay switching level using rotary selector

The 0 - 100% selector setting corresponds to the value of selected range – see example below.

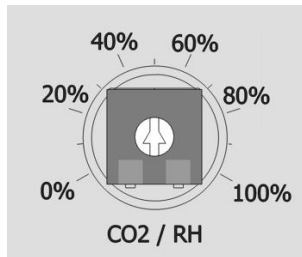

The relay switches on when the level of measured value rises above the level of the rotary selector. The relay switches off when the level measured value falls below the level of the rotary selector minus hysteresis value of 5% from measuring range. Minimal lag between changes in state relays are 2 minutes.

Selector value	TVOC [ $\mu\text{g}/\text{m}^3$ ] range 0 - 3000 $\mu\text{g}/\text{m}^3$
0%	0
10%	300
20%	600
30%	900
40%	1200
50%	1500
60%	1800
70%	2100
80%	2400
90%	2700
100%	3000

### Relay switching example for TVOC 0 – 3000 $\mu\text{g}/\text{m}^3$

- hysteresis 5% = 150  $\mu\text{g}/\text{m}^3$
- selected switching level value 50% (50% corresponds to 1500  $\mu\text{g}/\text{m}^3$ )

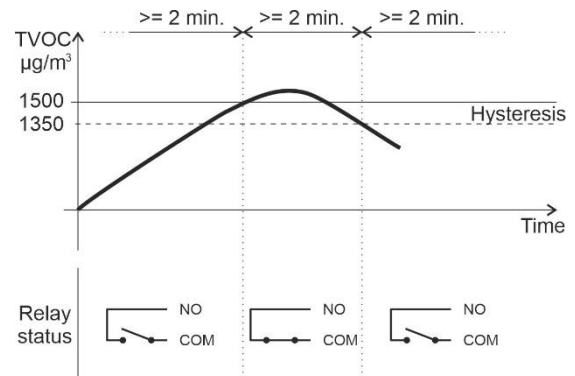

### Sensor connection using the output relay

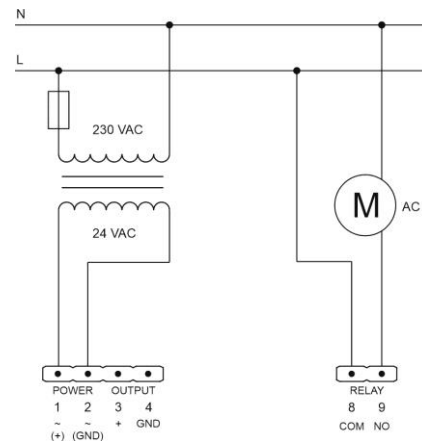

### Sensor connection - direct EC motor control using signal 0-10 V

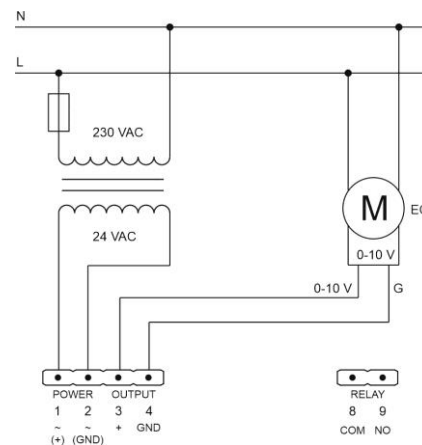

## NL-ECO-TVOC | Room sensor VOC

If you connect other devices to the same AC power source as the NL sensor, it is necessary to meet GND wiring of all analog inputs and outputs, as well as power wires.

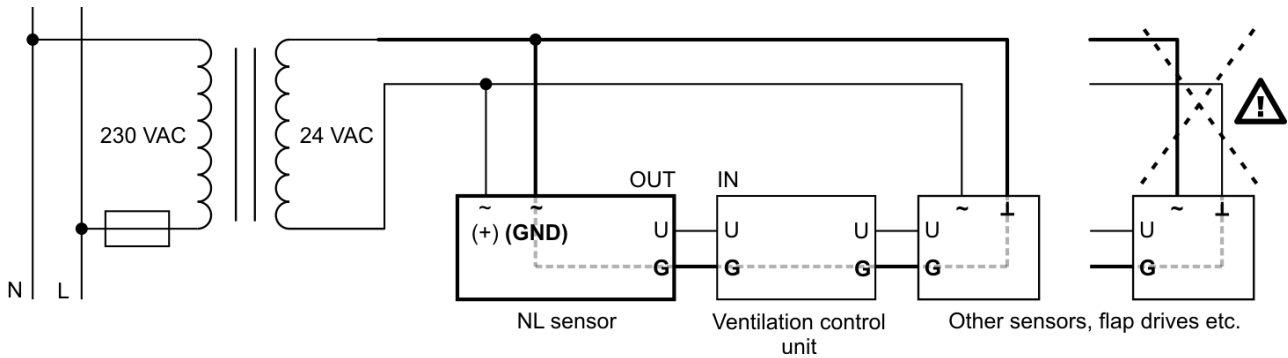

### Dimensions

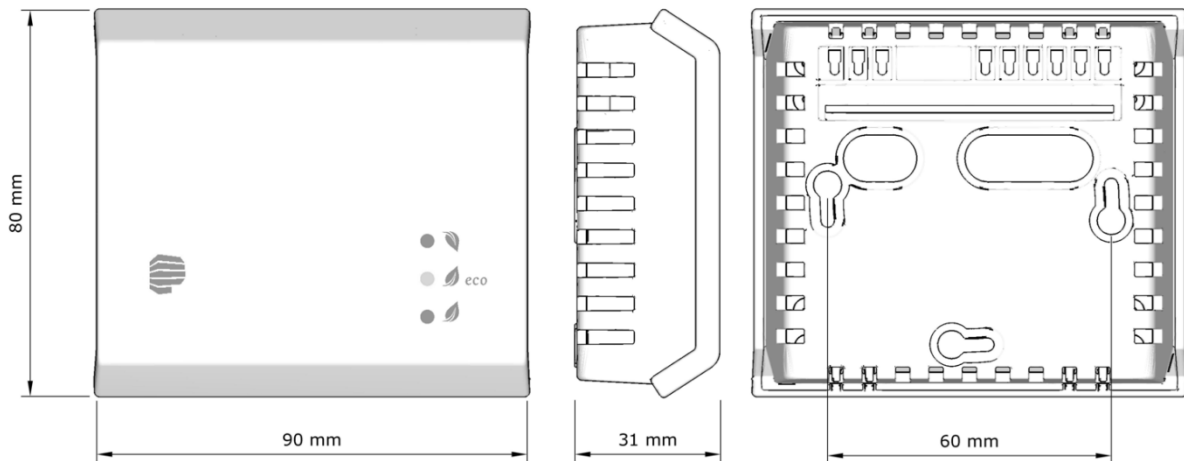

### Sensor assembly

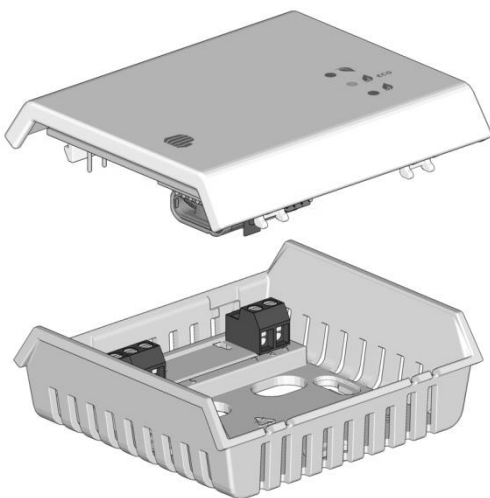

### Box color

Front: White - RAL9016. Base: gray - RAL7035.

### Way to use

The product is intended for indoor use only. You can read the [recommendations for sensor placement](#) on our web pages. It is necessary to avoid severe mechanical shock of the sensor.

### End of product life

Discard the product in according to the electronic waste law and the EU directives.

*The producer reserves the right of technical changes in order to product improvements its properties and functions without previous notice.*

