

## NL-ECO-CO2-BA | Room sensor CO<sub>2</sub> with BOOST regime and alarm

Room sensor NL-ECO-CO2-BA serves for continuous air quality monitoring inside buildings and for effective ventilation (HVAC) systems control according to actual level of air pollution. Sensor continuously monitors carbon dioxide (CO<sub>2</sub>) concentration in the air. It can be effectively used in offices, schools, classrooms, shopping centers, homes, restaurants, fitness centers, commercial buildings, etc.

- > measures CO<sub>2</sub>, optical principle NDIR
- > LED indication with automatic turn off according to ambient light (at night)
- > sound signalization – alarm
- > BOOST regime
- > analog voltage output 0-10V
- > output relay NO/C
- > maintenance or calibration not required during operation
- > long-term stability
- > expected lifetime >10 years

### Description

The measuring of CO<sub>2</sub> is based on the principle of infrared radiation attenuation dependence on the CO<sub>2</sub> concentration in the air (NDIR). Built-in auto-calibration function ensures very good long term stability. The sensor has one analog output for the actual concentration of CO<sub>2</sub>.

CO<sub>2</sub> concentration has very good telling ability about actual indoor air quality, therefore the sensor serves to effectively control ventilation and heat recovery units. The trigger level of CO<sub>2</sub> concentration output relay can be set by a rotary element in the entire measuring range. Relay switching can be indicated by a short (1,5s) sound signal 1x per minute, if the function is allowed.

BOOST regime allows you to manually set the ventilation to maximum power. Detailed description of functions can be found further in this manual. Current air quality can be easily checked by three LED indicators. When ambient light is dimmed, the indicators turn off automatically to not disturb you when falling asleep.

Explanation of abbreviations and technical terms can be found on our website in the [Glossary](#) section.



### Technical data

Parameter	Value	Unit
Supply voltage range	12–35	V DC
	12–24	V AC
Consumption	max 1,5	W
CO <sub>2</sub> measuring range <sup>1)</sup>	400 - 1000	ppm
	400 – 2000	
	400 – 5000	
CO <sub>2</sub> accuracy <sup>2)</sup>	- for ranges 400 – 1000 and 400 - 2000 ppm	± 40 ppm + ±4 % of reading
	- for range 400 - 5000 ppm	± 60 ppm + ±4 % of reading
	CO <sub>2</sub> relay - hysteresis	5 % from range (100ppm/250ppm)
CO <sub>2</sub> rate rise	max 1	min
CO <sub>2</sub> step response	(90 %) 80	s
Voltage output <sup>3)</sup>	0–10	V DC
Max. switching voltage	250/30	V AC / V DC
Max. switching current	5/5	A AC / A DC
Working humidity non condensing	0–95 %	RH
Working temperature	0 to +50	°C
Storage temperature	-20 to +60	°C
Expected lifetime	10	years
Ingress protection	IP20	
Dimensions	90x80x31	mm

<sup>1)</sup> Measuring range can be chosen by jumper setting.  
<sup>2)</sup> At 15 – 35 °C, 0-80% RH.  
<sup>3)</sup> Minimum achievable output value corresponds to minimum value of the measuring range.



**NL-ECO-CO2-BA | Room sensor CO<sub>2</sub> with BOOST regime and alarm**

**Voltage output versus CO<sub>2</sub> concentration for range 400 - 1000 ppm:**

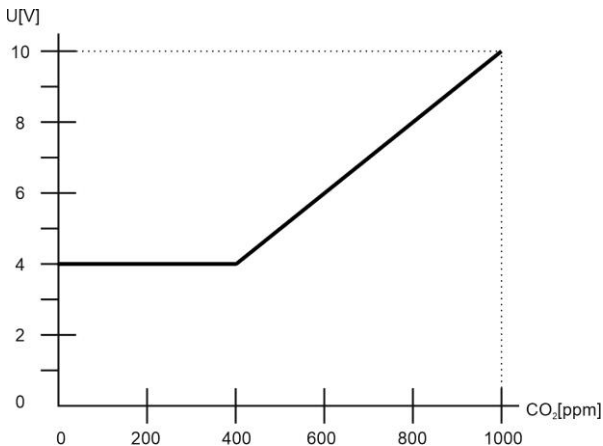

**Voltage output versus CO<sub>2</sub> concentration for range 400 - 2000 ppm:**

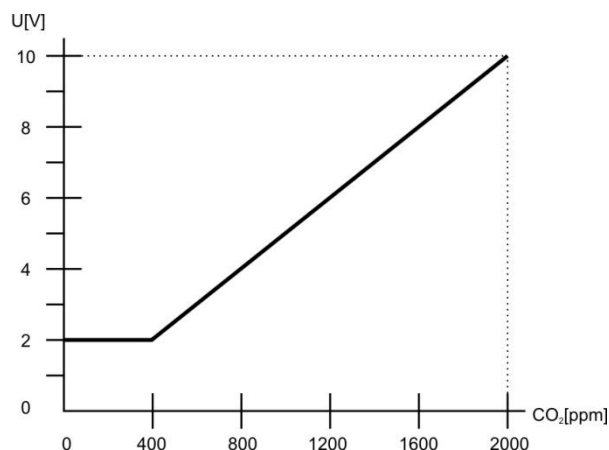

**Voltage output versus CO<sub>2</sub> concentration for range 400 - 5000 ppm:**

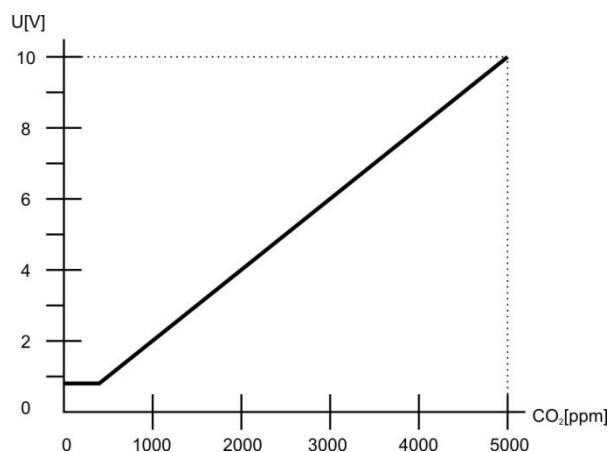

**CO<sub>2</sub> sensor autocalibration function**

Autocalibration compensates for long-term aging of the key components of the sensor. This function is available only during permanent sensor power supply. Calibration during operation throughout the lifetime of the sensor is not needed.

**LED indication description**

**White LED lights:**

- Less than 600 ppm CO<sub>2</sub>.
- excellent air quality, low concentrations of CO<sub>2</sub>
- maintaining this level is not cost-effective

**Green LED lights:**

- More than or equal to 600 ppm CO<sub>2</sub>, less than or equal to 1200 ppm CO<sub>2</sub>.
- optimal balance of air quality and energy consumption for ventilation and air condition
- maintaining the CO<sub>2</sub> concentration in this range does not significantly reduce the comfort of the indoor environment

**Yellow LED lights:**

- More than 1200 ppm CO<sub>2</sub>.
- higher concentration of CO<sub>2</sub> – lower air quality, that can cause feeling uncomfortable, restlessness, weakness, fatigue, headache, dizziness etc.
- 

**Sensor start after power on**

All three LEDs are shining simultaneously in the meantime, pending the availability of the first measured value. But no longer than 10 seconds. The sensor is fully operational after 1 minute since power on.

The declared accuracy is reached after 4 days of continuous power supply.

**Sensor failure indication**

All three LED's lights up at the same time permanently.



## NL-ECO-CO2-BA | Room sensor CO<sub>2</sub> with BOOST regime and alarm

### BOOST regime and alarm setting touch button

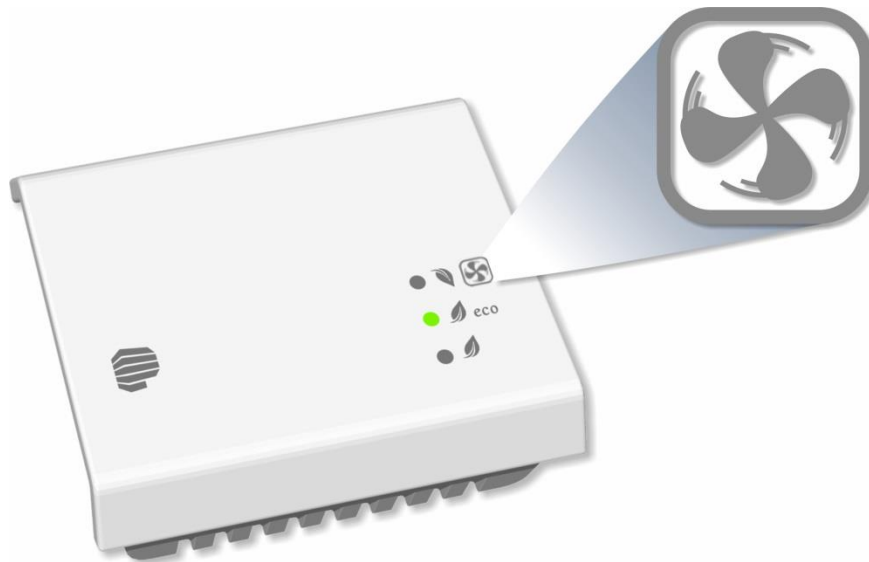

#### BOOST regime

This regime serves to set the sensor controlled ventilation to maximum power regardless of the actual concentration. In this regime the relay contacts are closed and output is set to maximum 10V DC.

BOOST regime is activated by a short touch of the button with fan symbol.

The siren beeps briefly to confirm that the button has been touched.

Active BOOST regime is indicated by yellow LED blinking – therefore the actual concentration is not indicated.

The regime is deactivated by repeating the procedure the same way. If the BOOST regime is not deactivated by user, it will be deactivated automatically after 20 minutes.

#### Sound signalization – alarm

Main function of sound signalization is to indicate that the set CO<sub>2</sub> level is exceeded, i.e. relay contacts are closed. Alarm function is activated and deactivated by the touch button.

For activation/deactivation of sound signalization hold your finger on the touch button with fan symbol on it.

At first siren beeps 1x shortly, then after 5s it beeps once per 1s for 5s. If it stops beeping after this action, alarm was just deactivated. If it will beep continuously, alarm was just activated. Now the button can be released.

From factory the alarm is set as active.

If the automatic mode of LED signalization is selected, alarm will be active only when the LED signalization is active – i.e. during daytime. At night, when the ambient lighting decreases and the signalization is turned off as such, alarm is also deactivated. If the LED indication is set to “always”, LED signalization and alarm will be active constantly, even in the dark. In both cases the condition is activation of alarm by the touch button.



**NL-ECO-CO2-BA | Room sensor CO<sub>2</sub> with BOOST regime and alarm**

**Electronic board controls and terminals**

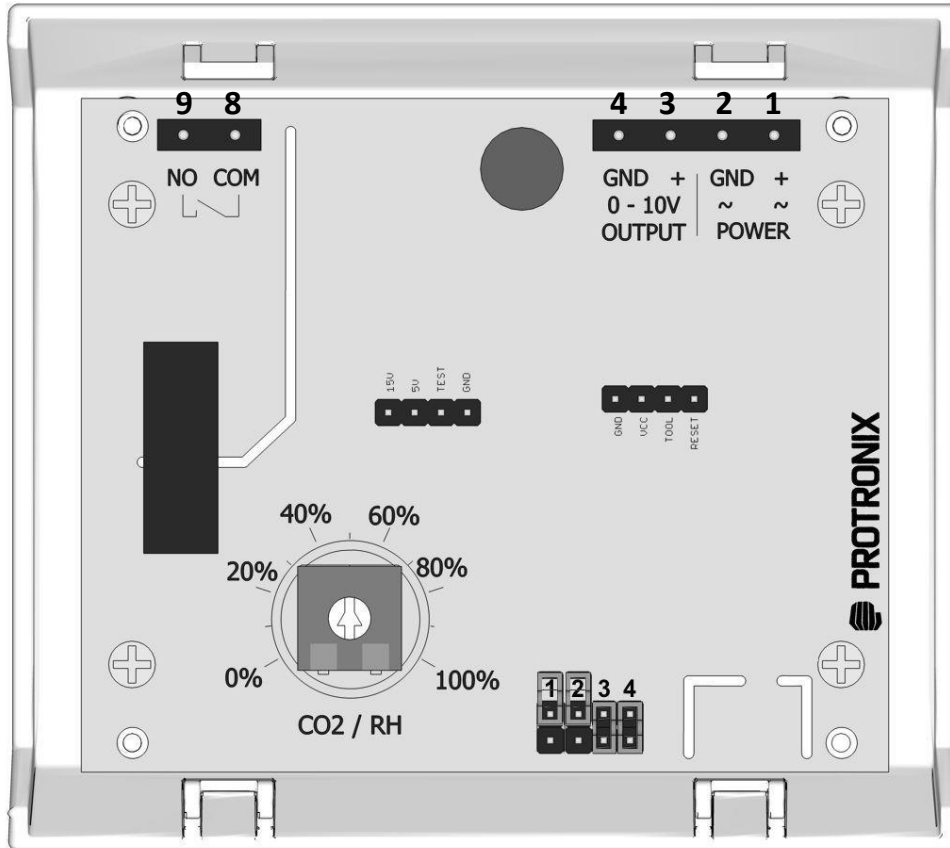

**Terminals**

**POWER**

<b>1. ~ +</b>	supply AC or DC (+) plus pole
<b>2. ~ GND</b>	supply AC or DC (-) minus pole, GND

**OUTPUT**

<b>3. +</b>	analog output 0-10 V
<b>4. GND</b>	output – minus pole, GND



<b>8. COM</b>	output relay, common contact
<b>9. NO</b>	output relay, normally open contact

**Jumpers**

jumper	meaning	fitted	not fitted
<b>2</b>	LED indication	always	automatic
<b>3</b>	autocalibration	enabled	disabled

**Measuring range setting**

range	jumper 1	jumper 4
400 – 1000 ppm	closed	open
400 – 2000 ppm	open	closed
400 – 5000 ppm	open	open

**Factory setting**

LED indication	automatic
Autocalibration	enabled
Switching level	50%
Measuring range	2000 ppm CO <sub>2</sub>



**NL-ECO-CO2-BA | Room sensor CO<sub>2</sub> with BOOST regime and alarm**

**Setting the relay switching level using rotary selector**

The 0 - 100% selector setting corresponds to the value of selected CO<sub>2</sub> measuring range – see example below.

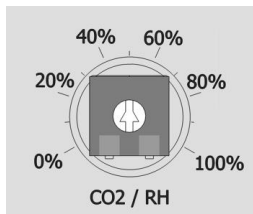

The relay switches on when the level measured value rises above the level of the rotary selector.  
The relay switches off when the level measured value falls below the level of the rotary selector minus hysteresis value of 5% from measuring range.  
Minimal lag between changes in state relays are 2 minutes.

Selector value	CO <sub>2</sub> (1000pm)	CO <sub>2</sub> (2000pm)	CO <sub>2</sub> (5000pm)
0 %	0	0	0
10 %	100	200	500
20 %	200	400	1000
30 %	300	600	1500
40 %	400	800	2000
50 %	500	1000	2500
60 %	600	1200	3000
70 %	700	1400	3500
80 %	800	1600	4000
90 %	900	1800	4500
100 %	1000	2000	5000

**Relay switching example – selected measuring range 2000ppm, hysteresis 5% = 100ppm, selected switching level value 50% (50% correspond to 1000ppm CO<sub>2</sub>)**

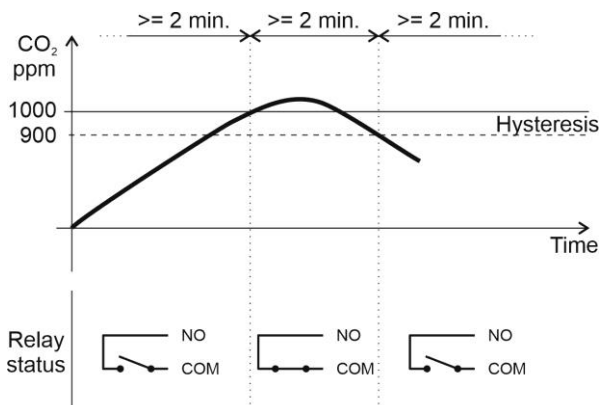

**Sensor connection using the output relay**

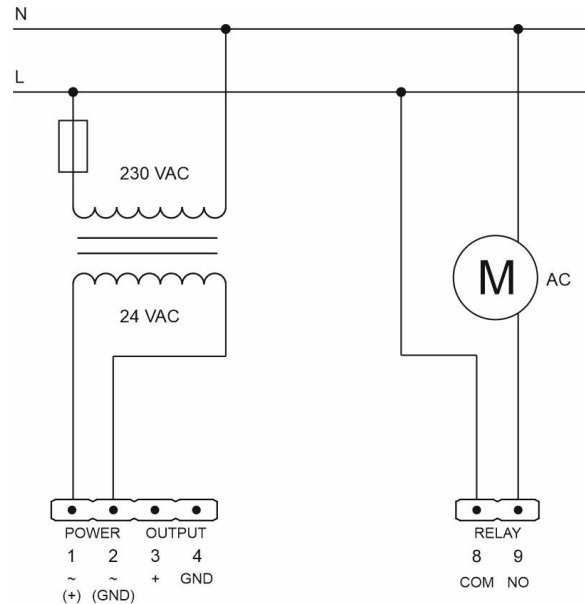

**Sensor connection - direct EC motor control using signal 0-10 V**

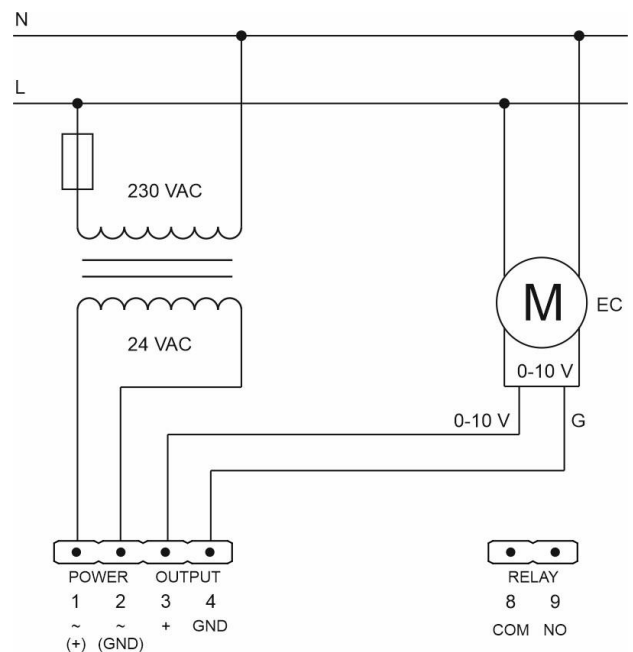

## NL-ECO-CO2-BA | Room sensor CO<sub>2</sub> with BOOST regime and alarm

If you connect other devices or more sensors to the same AC power source as the NL sensor, it is necessary to meet GND wiring of all analog inputs and outputs, as well as power wires.

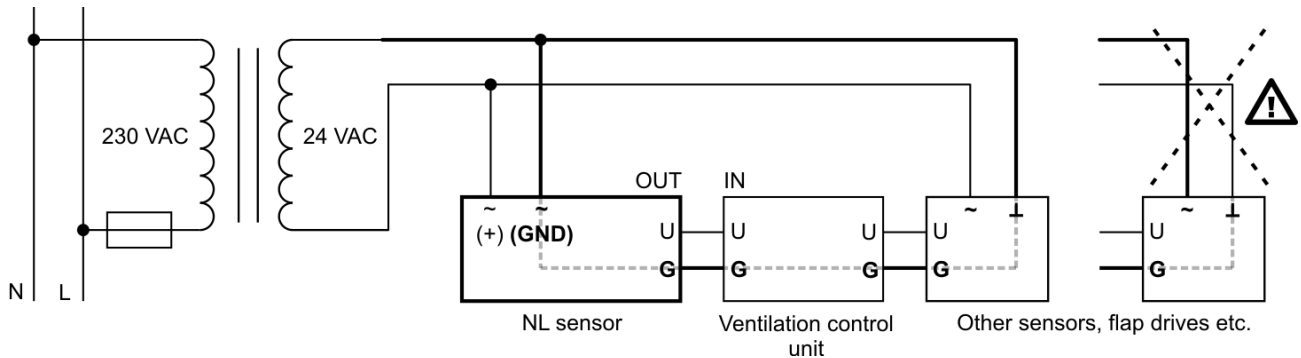

### Dimensions

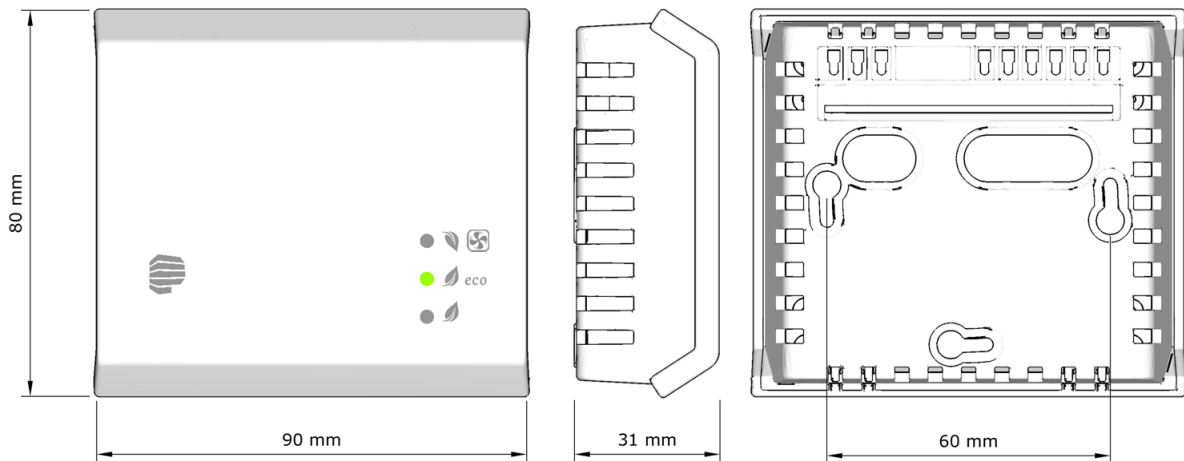

### Sensor assembly

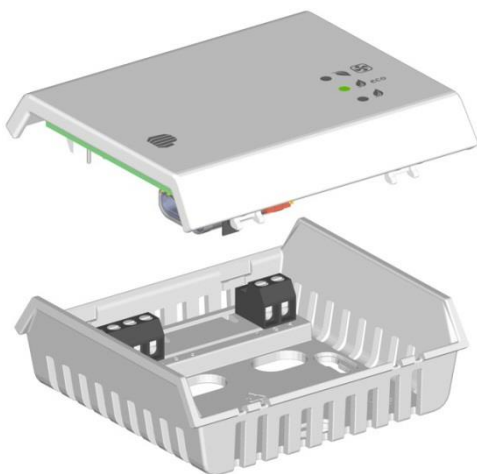

### Box color

Front: white - RAL9016. Base: gray - RAL7035.

### Way to use

The product is intended for indoor use only. You can read the [recommendations for sensor placement](#) on our web pages. It is necessary to avoid severe mechanical shock of the sensor.

### End of product life

Discard the product in according to the electronic waste law and the EU directives.

*The producer reserves the right of technical changes in order to product improvements its properties and functions without previous notice.*

