

NL-ECO-CO2-230 | Room sensor CO₂ 230V

Room sensor NL-ECO-CO2-230V is used for indoor air quality monitoring and for effective control of ventilation (HVAC) systems according to actual air quality. The sensor measures concentration of carbon dioxide (CO₂) in air. It can be effectively used in offices, classrooms, shopping centers, homes, restaurants, fitness centers, commercial buildings, etc.

- > measures CO₂
- > precise optical principle NDIR
- > LED indication with automatic turn off at night
- > analog voltage output 0-10V
- > output relay NO/C
- > maintenance or calibration not required during operation
- > long-term stability
- > verified lifetime >10 years

Description

The measuring of CO₂ is based on the principle of infrared radiation attenuation dependence on the CO₂ concentration in the air (Non Dispersive Infra Red).

Built-in auto-calibration function ensures very good long term stability.

The sensor has one analog output for the actual CO₂ concentration.

Ventilation and heat recovery units can be effectively controlled based on the output signal of the sensor in very efficient way.

The trigger level of CO₂ concentration output relay is set by a rotary element.

Current air quality can be easily checked by three LED indicators with built-in automatic shut-off at night.

Explanation of abbreviations and technical terms can be found on our website in the [Glossary](#) section.



Technical data

Parameter	Value	Unit
Power supply	230	V AC
Power consumption	max 1,5	W
CO ₂ measuring range ¹⁾	400 – 1000 400 – 2000 400 – 5000	ppm
CO ₂ accuracy ²⁾	- for ranges 400 – 1000 and 400 - 2000 ppm - for range 400 - 5000 ppm	± 40 ppm + ±4 % of reading ± 60 ppm + ±4 % of reading
CO ₂ relay - hysteresis	5 % from range (100ppm/250ppm)	
CO ₂ rate rise	max 1	min
CO ₂ step response	(90 %) 80	s
Voltage output ³⁾	0 – 10	V DC
Max. switching voltage	250/30	V AC / V DC
Max. switching current	5/5	A AC / A DC
Working humidity non condensing	0 – 95 %	RH
Working temperature	0 to +50	°C
Storage temperature	-20 to +60	°C
Expected lifetime	10	years
Ingress protection	IP20	
Dimensions	90x80x31	mm

¹⁾ Measuring range can be chosen by jumper setting. Default range is 400 - 2000ppm.
²⁾ At 15 – 35 °C, 0-80% RH.
³⁾ Minimum achievable output value corresponds to minimum value of the measuring range.



NL-ECO-CO2-230 | Room sensor CO₂ 230V

Voltage output versus CO₂ concentration for range 400 - 1000 ppm:

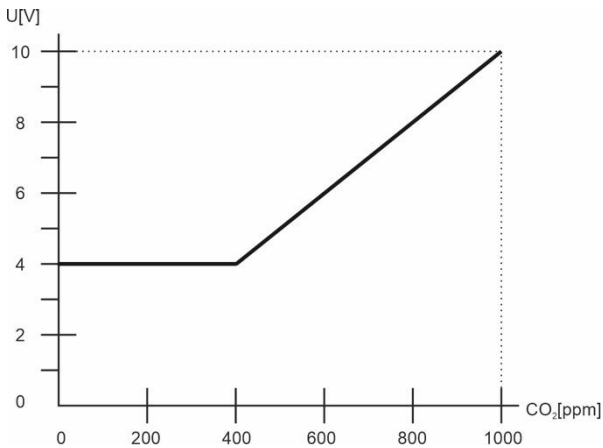

Voltage output versus CO₂ concentration for range 400 - 2000 ppm:

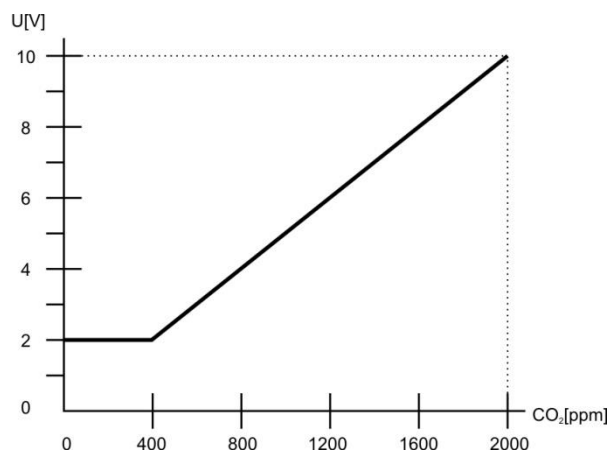

Voltage output versus CO₂ concentration for range 400 - 5000 ppm:

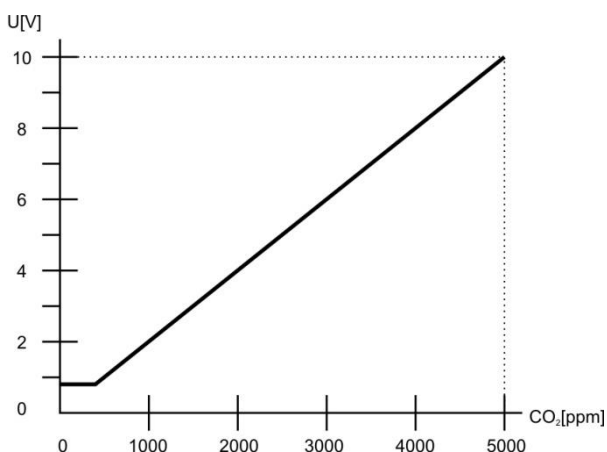

CO₂ sensor autocalibration function

Autocalibration compensates for long-term aging of the key components of the sensor. This function is active during permanent sensor power supply. Calibration during operation throughout the whole lifetime of the sensor is not needed.

LED indication description

White LED lights:

- Less than 600 ppm CO₂.
- excellent air quality, low concentrations of CO₂
 - maintaining this level is not cost-effective, especially during the winter

Green LED lights:

- More than or equal to 600 ppm CO₂, less than or equal to 1200 ppm CO₂.
- optimal balance of air quality and energy consumption for ventilation and air conditioning
 - maintaining the CO₂ concentration in this range does not significantly reduce the comfort of the indoor environment

Yellow LED lights:

- More than 1200 ppm CO₂.
- higher concentration of CO₂ – lower air quality, this can already cause negative effects associated with low air quality such as restlessness, weakness, fatigue, headache, dizziness etc.

Sensor start after power on

All three LEDs are shining simultaneously in the meantime, pending the availability of the first measured value. But no longer than 10 seconds. The sensor is fully operational after 1 minute since power on.

The declared accuracy is reached after 4 days of continuous power supply.

Sensor failure indication

All three LED's lights up at the same time permanently.



NL-ECO-CO2-230 | Room sensor CO₂ 230V

Electronic board controls and terminals

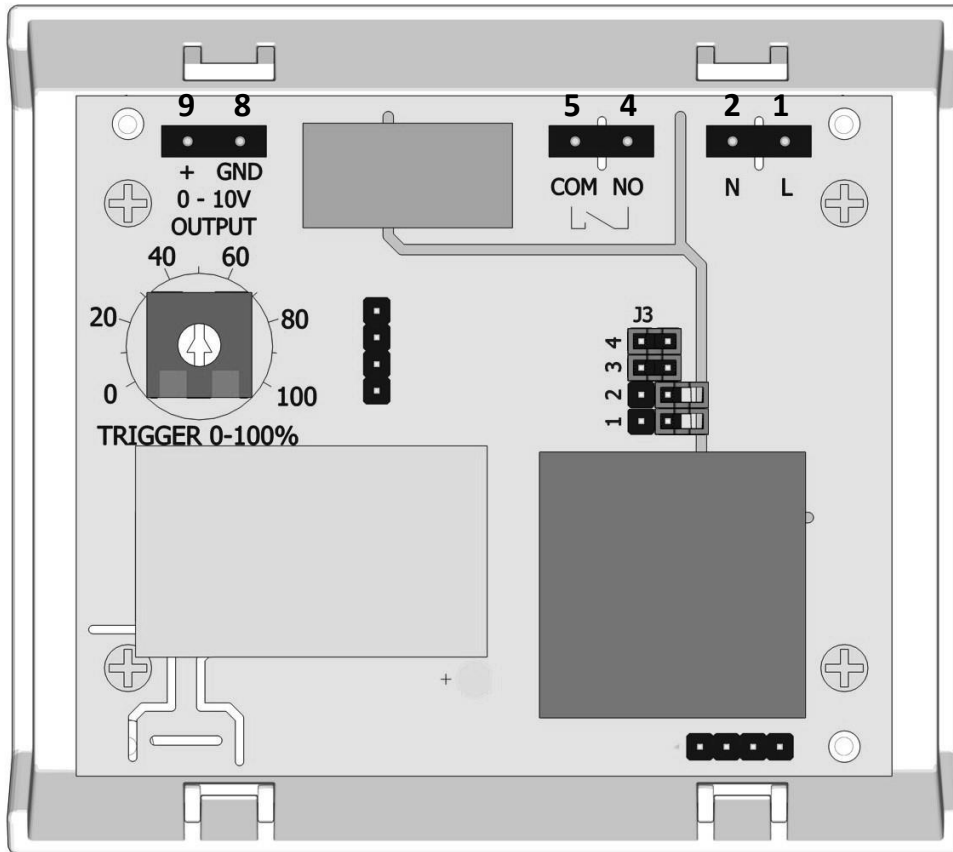

Terminals

POWER

1. L	supply AC - L
2. N	supply AC - N



4. NO	output relay, normally open contact
5. COM	output relay, common contact

OUTPUT

8. GND	output – minus pole, GND
9. +	analog output 0-10 V

Jumpers J3

jumper	meaning	fitted	not fitted
2	LED indication	always	automatic
3	autocalibration	enabled	disabled

Measuring range setting

range	jumper 1	jumper 4
400 – 1000 ppm	closed	open
400 – 2000 ppm	open	closed
400 – 5000 ppm	open	open

Factory setting

LED indication	automatic
Autocalibration	enabled
Switching level	50%
Measuring range	2000 ppm CO ₂



NL-ECO-CO2-230 | Room sensor CO₂ 230V

Setting the relay trigger level using rotary selector

The 0 - 100% selector setting corresponds to the value of selected CO₂ measuring range – see example below.

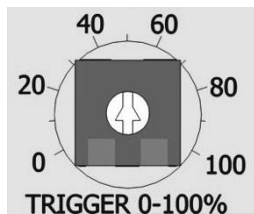

The relay switches on when the measured value rises above the trigger level.
The relay switches off when the measured value falls below the trigger level minus hysteresis value (5% from measuring range).
Minimal lag between relay state - changes is 2 minutes.

Selector value	CO ₂ (1000ppm)	CO ₂ (2000ppm)	CO ₂ (5000ppm)
0 %	0	0	0
10 %	100	200	500
20 %	200	400	1000
30 %	300	600	1500
40 %	400	800	2000
50 %	500	1000	2500
60 %	600	1200	3000
70 %	700	1400	3500
80 %	800	1600	4000
90 %	900	1800	4500
100 %	1000	2000	5000

Relay switching example – selected measuring range 2000ppm, hysteresis 5% ~ 100ppm, selected switching level value 50% (50% correspond to 1000ppm CO₂)

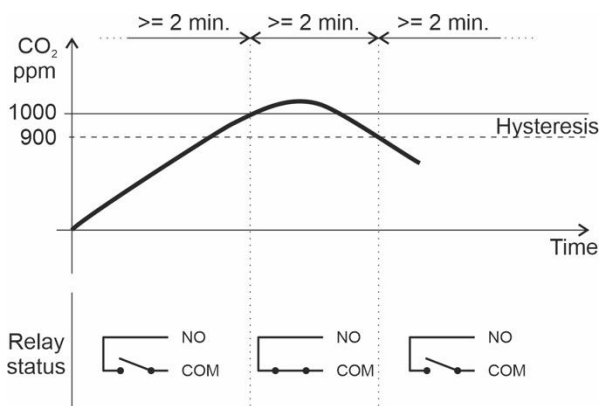

Sensor connection using the output relay

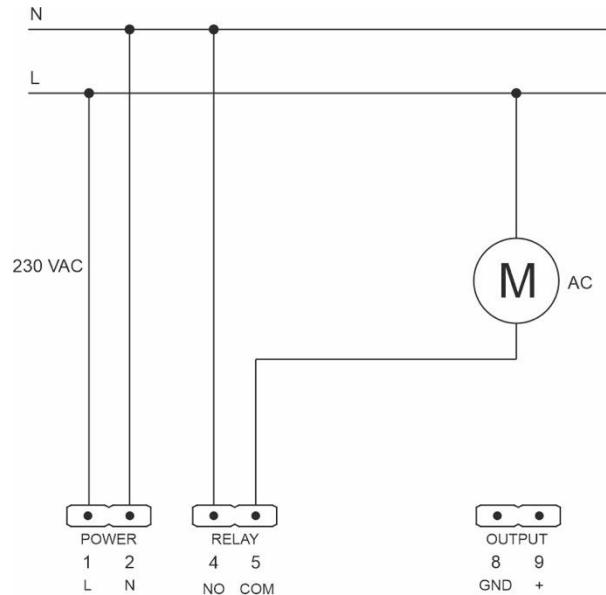

Sensor connection - direct EC motor control using signal 0-10 V

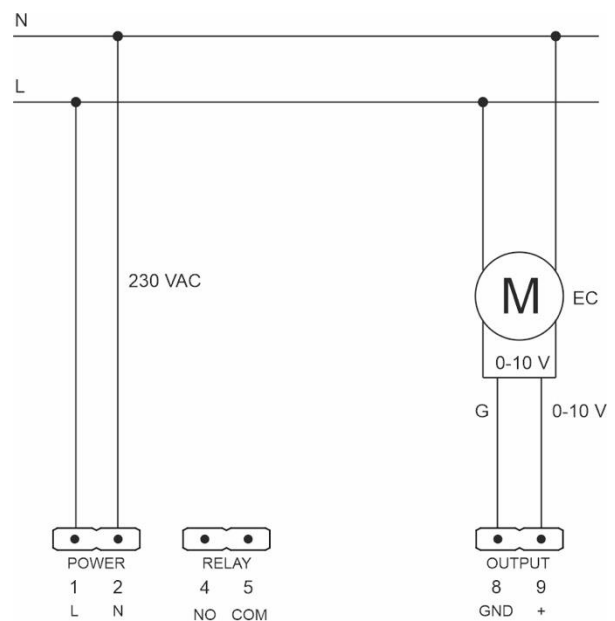

NL-ECO-CO2-230 | Room sensor CO₂ 230V

Sensor box disassembly

Push on the two locks with a flat head screwdriver to release the upper part of the box. Then, tilt it in the indicated direction (see the picture below).

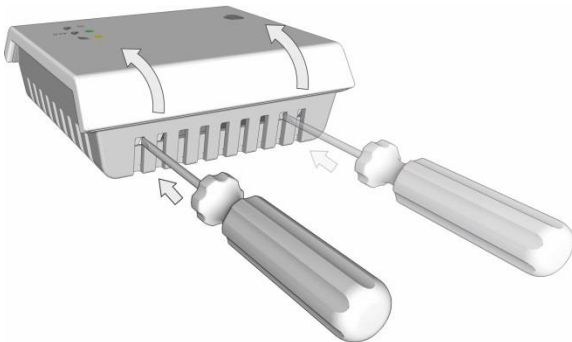

Continue to move the upper part with all the electronics until it is separated from the lower part.

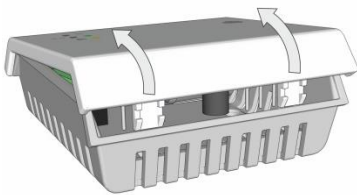

Box color

White - RAL9016.

Way to use

The product is intended for indoor use only. You can read the [recommendations for sensor placement](#) on our web pages.

CAUTION:

It is necessary to avoid severe mechanical shock of the sensor.

End of product life

Discard the product in according to the electronic waste law and the EU directives.

Dimensions

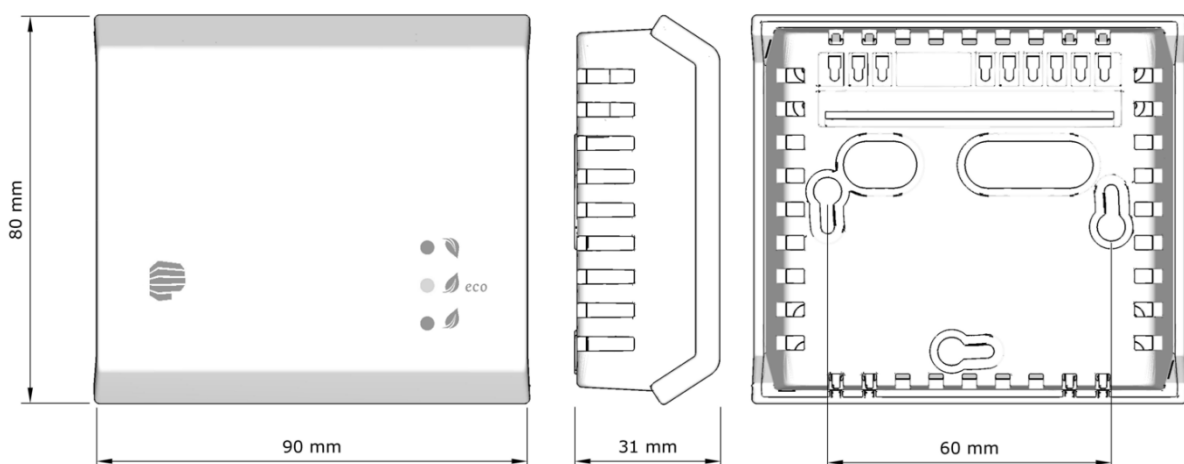

The producer reserves the right of technical changes in order to product improvements its properties and functions without previous notice.

